

**INTORQ**

setting the standard



## **BFK 470 spring-applied brake**

The IP66 modular system

2 - 370 Nm

[www.intorq.com](http://www.intorq.com)

## We set the standards

The INTORQ brand stands for reliable brake solutions with the highest product standards. INTORQ products are used in a very diverse range of applications, from brake motors and industrial trucks to hoists, cranes and wind turbines. We can create the right solution for you and your drive – individually and reliably.

The INTORQ module system offers numerous variants that can be used in many motors and geared motors, setting standards worldwide. We have been increasing our international presence step by step, establishing sites in Shanghai, Atlanta and Pune. So our network of sales and service staff is close at hand all over the world, ready to support you.



### INTORQ at a glance

- Electromagnetic brakes and clutches
- Flexibility with standard options as well as customised solutions
- Centralised product development and production located in aerzen
- Fast response and delivery times globally thanks to production and warehousing in Shanghai, Atlanta and Pune.
- Over 50 million euros a year sales volume
- 800,000 units a year
- 13,000 square metres production area
- 250 employees
- Market leader with 63 sales partners in 49 countries



## BFK470 – for harsh operating conditions

With the BFK470, the INTORQ product portfolio now offers a modular series of spring-applied brakes sealed by an IP66 enclosure. This new series was developed for operating conditions that require a high level of ingress protection against dust and/or dampness.

The BFK470 comes in 7 sizes from 2 – 370 Nm. As a self-contained system, it is predestined for use in wind turbines and cranes. This brake can also be used in extreme ambient temperatures.

### The modular system

Our modular solutions are unique in the market, and they have been put to successful use for decades. The BFK470 also comes with a guarantee of maximum flexibility and fast worldwide availability.

### Features

- Enclosure complies with IP66, also available with hand-release
- Mountable rotary transducer (optional)
- Can be used in temperatures up to minus 40°C (Cold Climate Version, CCV)
- Inductive proximity sensor for function monitoring
- Increased maximum torques and long life cycle through the refined mechanical structure
- Compatible with corrosion protection class C4 or C5

### Fields of application

- Brake motors
- Wind turbines
- Car wash systems
- Cranes
- Hoists
- Textile machines



## INTORQ BFK470-□□ product key

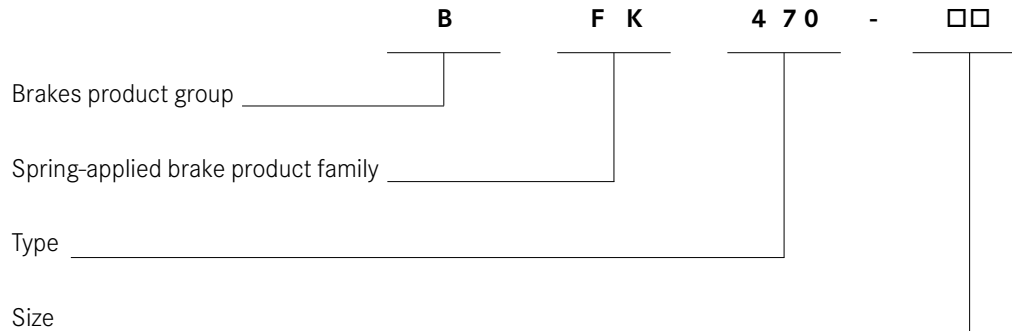

### Sizes

06, 08, 10, 12, 14, 16, 18

### Certificates

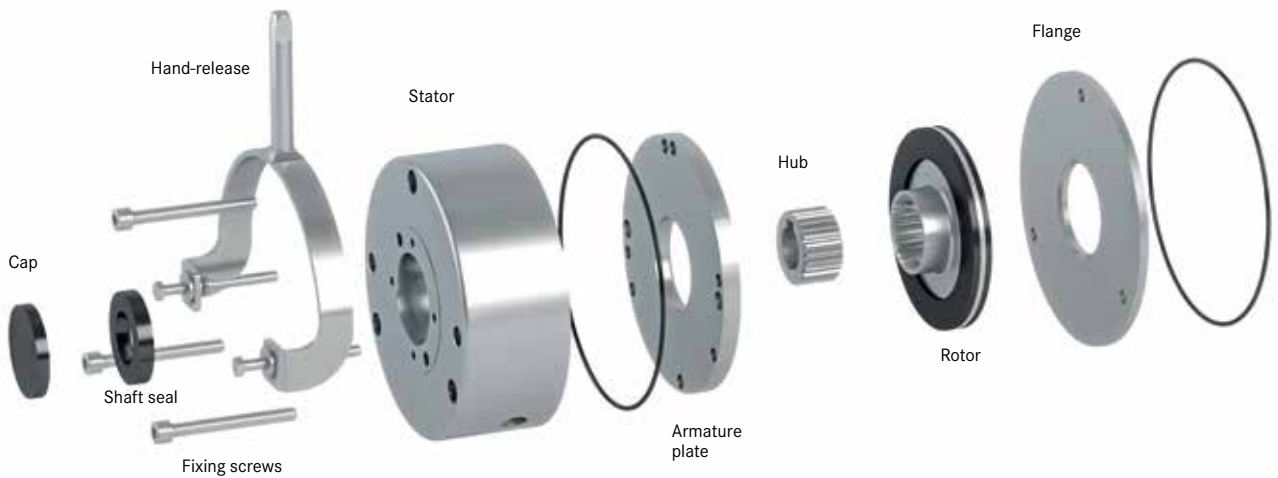

### List of abbreviations

<b>P<sub>N</sub></b>	[W]	Rated coil power at rated voltage and 20°C	<b>S<sub>nmax</sub></b>	[1/h]	Maximum permissible operating frequency, depending on the friction work per operation
<b>U<sub>N</sub></b>	[V DC]	Rated coil voltage	<b>S<sub>LN</sub></b>	[mm]	Rated air gap
<b>M<sub>dyn</sub></b>	[Nm]	Dynamic brake torque, measured at constant speed of rotation	<b>S<sub>Lmax</sub></b>	[mm]	Maximum air gap
<b>M<sub>K</sub></b>	[Nm]	Rated torque of the brake, at a relative speed of 100 r/min	<b>t<sub>1</sub></b>	[s]	Engagement time, the total of the reaction delay and torque rise time $t_1 = t_{11} + t_{12}$
<b>Δn<sub>0</sub></b>	[r/min]	Initial relative speed of the brake	<b>t<sub>2</sub></b>	[s]	Disengagement time, time from switching the stator until the torque has reduced to 0.1 M <sub>K</sub>
<b>Q</b>	[J]	Heat/energy	<b>t<sub>3</sub></b>	[s]	Slipping time to standstill (after t <sub>11</sub> )
<b>Q<sub>E</sub></b>	[J]	Maximum permissible friction work per switching cycle, thermal rating of the brake	<b>t<sub>11</sub></b>	[s]	Delay time when connecting, time from disconnecting the voltage until the torque begins to rise
<b>Q<sub>smax</sub></b>	[J]	Maximum permissible friction work during cyclic switching, depending on the operating frequency	<b>t<sub>12</sub></b>	[s]	Rise time of braking torque, time from beginning of rise of torque until braking torque is reached
<b>S<sub>h</sub></b>	[1/h]	Operating frequency, the number of repeated operations per unit time			

## Product information

### Powerful portfolio

- 7 sizes
- Standard voltages [V DC] 24, 103, 180, 205
- Graduated torque range from 2 - 370 Nm
- Enclosure complies with up to IP66

### Torque transmission

- Friction locking in dry running

### Fast and easy mounting

- Air gap preset
- Rated torques are achieved after only a few switching cycles, thanks to special machining of the friction surfaces
- Fixed bearing is not required on the brake

### Mechanical design

- Insulation system complies with temperature class F (155 °C) and ensures that the winding has a long service life
- The brakes are designed for 100 % duty cycle (current-control brake)
- Long, low-wear rotor-hub connection with tried and tested involute gear
- Low-wear, asbestos-free, solvent-free friction linings

### Options

- Hand-release complying with IP66 enclosure for manual release over all sizes, release is possible in both directions
- Noise-reduced rotor
- Function monitoring through contactless proximity sensor complying with IP66, ambient temperature range: -25°C to +120°C (available from size 12)
- Non-standard voltages and bores on request
- Pulse width modulation (PWM)  
Partial discharge free brake has been developed for operation with the pulse width modulated DC bus voltage of a frequency inverter  
Rated coil voltage  $U_N=103V$  DC

### Temperature-resistant up to minus 40 °C

- CCV (Cold Climate Version) optional
- Option for non-contact proximity sensor:  
Information evaluation only for range -25°C to +120°C

### Corrosion protection up to class C5

- Ready for coating, in accordance with norm EN ISO 12944
- Corrosion protection class C4 or C5, depending on the coating system used



BFK470 with  
shaft seal



BFK470 with  
hand-release

# Technical data

## BFK470 spring-applied brake

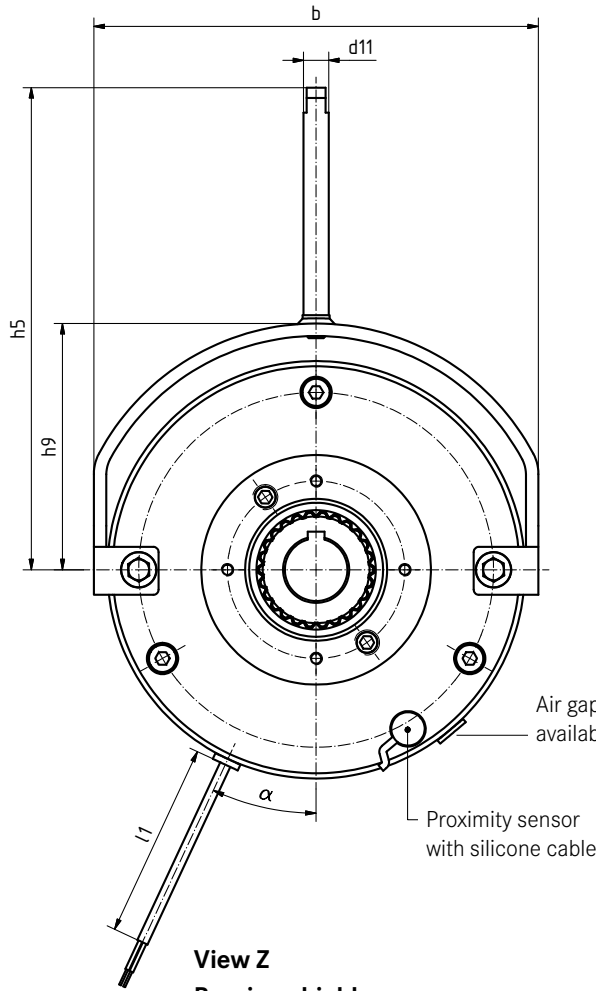

**View Z**  
Bearing shield

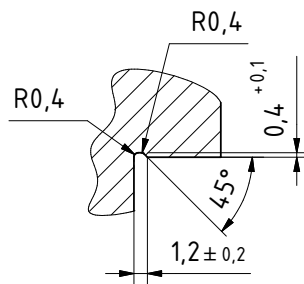

## Brake with flange

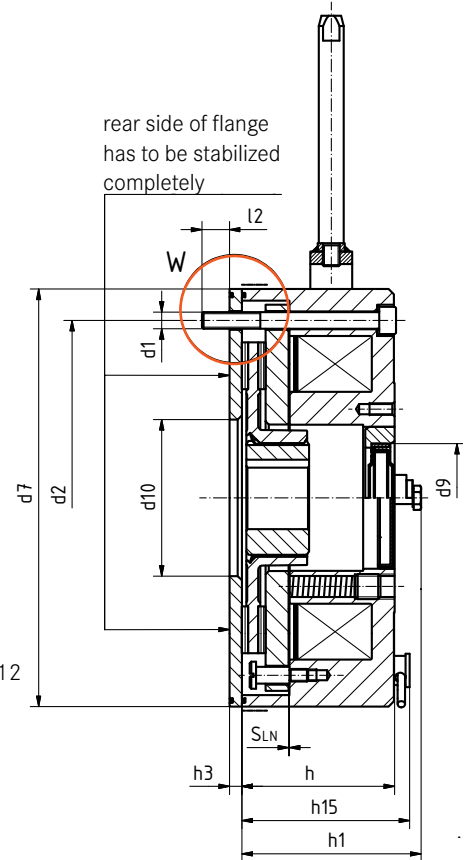

**View W**  
with centering

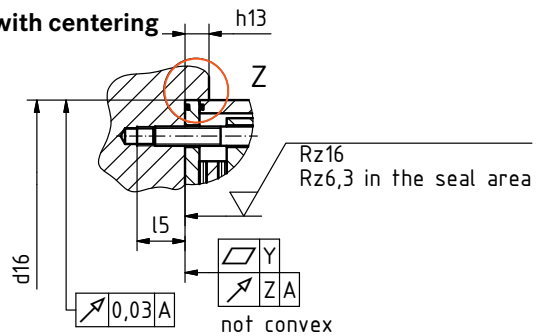

Size	b	d1 <sup>1)</sup> spec.	d <sup>H7</sup> 2) standard	d <sub>1</sub>	d <sub>2</sub>	d <sub>3</sub>	d <sub>4</sub>	d <sub>5</sub> <sup>H7</sup>	d <sub>6</sub>	d <sub>7(-0,2/-0,3)</sub>	d <sub>9</sub>	d <sub>10</sub>	d <sub>11</sub>	d <sub>14</sub>	d <sub>15</sub>	d <sub>16</sub> <sup>H8</sup>	d <sub>17</sub> <sup>H8</sup>	d <sub>18</sub> <sup>H8</sup>	d <sub>19</sub>	d <sub>i</sub>	d <sub>a</sub>	h	h <sub>1</sub>
06	95	10	10/11/12/14/15	3xM4	72	24 H8	48	89	89	89	-	31	8	4xM4	37,7	89	35	89	94	40	60	39	45,2
08	112	10	10/11/12/14/15/16/17/18/19/20	3xM5	90	32 H8	58	106	106	106	-	42	8	4xM5	49	106	42	106	111	56,1	76,5	43	50
10	137	10	10/11/12/14/15/16/17/18/19/20	3xM6	112	42 H8	68	130	130	130	-	44	10	4xM5	54	130	44	130	136	66,1	95	51,2	59,35
12	157	14	14/15/18/20/22/24/25	3xM6	132	52 H7	82	148	148	148	-	52	12	4xM5	64	148	55	148	154	70,1	115	57,2	65,4
14	179	14	20/25/30	3xM8	145	60 H7	100	168	168	168	52	64	12	4xM6	75	168	70	168	175	80	124	67,1	75,3
16	213	15	25/30/35	3xM8	170	68 H7	110	200	200	200	52	74	12	4xM6	85	200	75	200	208	104	149	73,1	85,8
18	243	20	30/35/40/45	6xM8	196	75 H7	125	226	226	226	62	95	14	4xM8	95	226	95	226	235	129	174	83,1	96,4

<sup>1)</sup> Predrilled without keyway

<sup>2)</sup> Standard keyway in accordance with DIN 6885/1 P9

For high torques and/or reversing mode it is necessary to use a special hub

**Brake without flange**

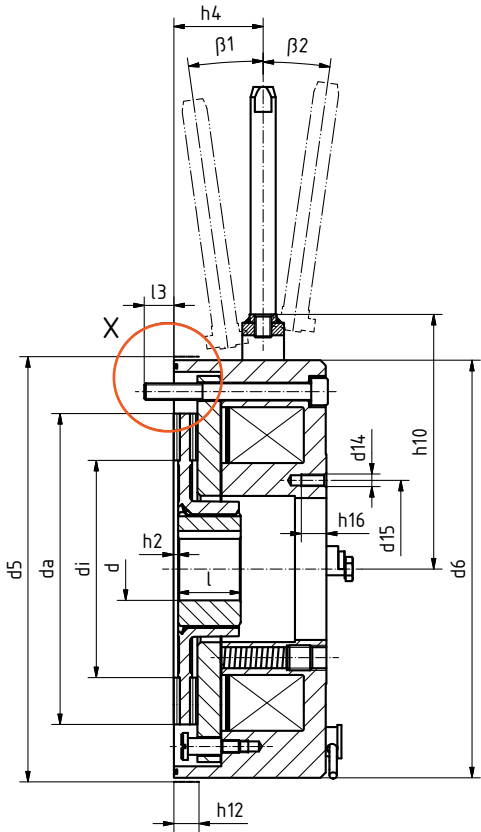

**Brake with centering flange**

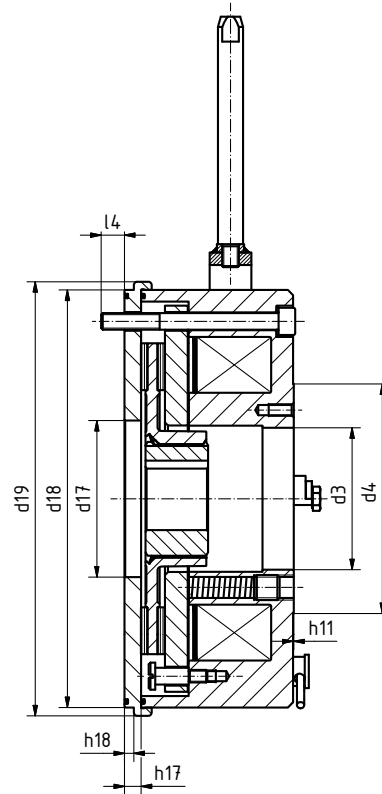

**Motor mounting plate  
(position tolerance of the screw holes)**

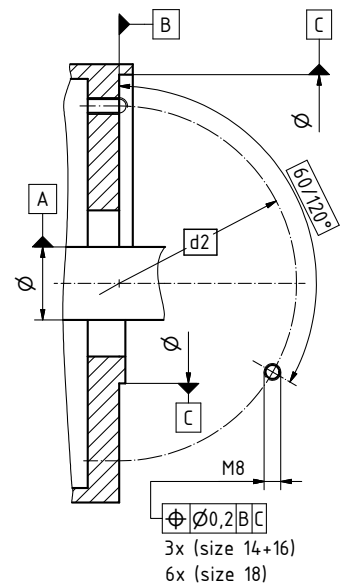

**View W  
without centering**

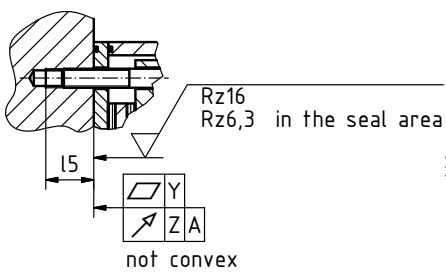

**View X  
with centering**

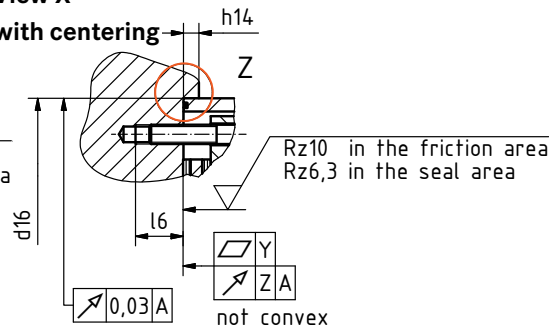

**View X  
without centering**

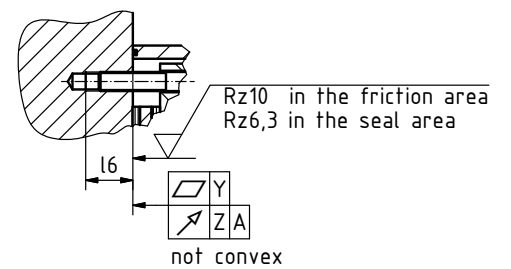

Size	h <sub>2</sub>	h <sub>3</sub>	h <sub>4</sub>	h <sub>5</sub>	h <sub>9</sub>	h <sub>10</sub>	h <sub>11</sub>	h <sub>12</sub>	h <sub>13 min.</sub>	h <sub>13 max.</sub>	h <sub>14 min.</sub>	h <sub>14 max.</sub>	h <sub>15</sub>	h <sub>16</sub>	h <sub>17</sub>	h <sub>18</sub>	l	l <sub>1</sub>	l <sub>2</sub>	l <sub>3</sub>	l <sub>4</sub>	l <sub>5 min.</sub>	l <sub>6 min.</sub>	S <sub>LN</sub>	α	β <sub>1</sub> +3°	β <sub>2</sub> +3°	Y	Z
06	1	3,5	20,7	112	54,5	57	0,3	8	6,5	9,5	4,5	6	-	10	4,5	3	18	400	6,8	5,3	5,8	9	7,5	0,2 (+0,08/-0,05)	25°	8,5°	8°	0,03	0,05
08	1	4,5	24,7	119,5	62	64,5	0,3	8	7,5	10,5	4,5	6	-	12	4,5	3	20	400	7,3	7,8	7,8	10	10,5	0,2 (+0,08/-0,05)	25°	8,5°	8°	0,03	0,05
10	2	4,5	26,9	143	77	80	0,3	10	8	12,5	4,5	8	-	12	6,5	4	20	400	10,2	10,7	8,7	13,5	14	0,2 (+0,13/-0,05)	25°	8°	7°	0,03	0,05
12	2	5	30,4	175	90	94	0,3	12	8,5	15	5,0	10	72,0	12	6,5	4	25	400	9,1	9,1	7,6	12,5	12,5	0,3 (+0,08/-0,10)	25°	8,5°	8°	0,05	0,05
14	2	6	38,8	185,5	100,5	104,5	0,3	12	10	16	6,5	10	79,4	12	8	4,5	30	400	14,3	15,3	12,3	19	20	0,3 (+0,10/-0,10)	25°	9°	8°	0,05	0,05
16	2,25	6	42,8	231	118	122	0,3	12	10	16	6,5	10	81,5	12	8	4,5	30	600	13,2	14,2	11,2	17	18	0,3 (+0,15/-0,05)	25°	8°	8°	0,08	0,05
18	2,75	6	47,8	290	135	140	0,3	12	10	16	6,5	10	91,6	16	10	5	35	600	19,3	15,3	15,3	23	19	0,4 (+0,20/-0,10)	25°	10°	9°	0,1	0,08

Measurements in mm

For a key to abbreviations see page 4

## Principle of operation

### BFK470 spring-applied brake

BFK470 spring-applied brakes are electrically releasable single disc brakes with two friction surfaces. In a de-energised state, the two friction surfaces of the rotor are stretched between the armature plate and flange by the force of the pressure springs. The braking torque comes from the friction radius of the rotor and is transmitted to the shaft via a hub with axial gear teeth. In this braked state, there is an  $s_L$  air gap between the armature plate and the stator. To release the brake, the coil of the stator is excited with DC voltage. The resulting magnetic flux acts against the spring force and pulls the armature plate onto the stator. This releases the rotor from the spring force, allowing it to move freely.

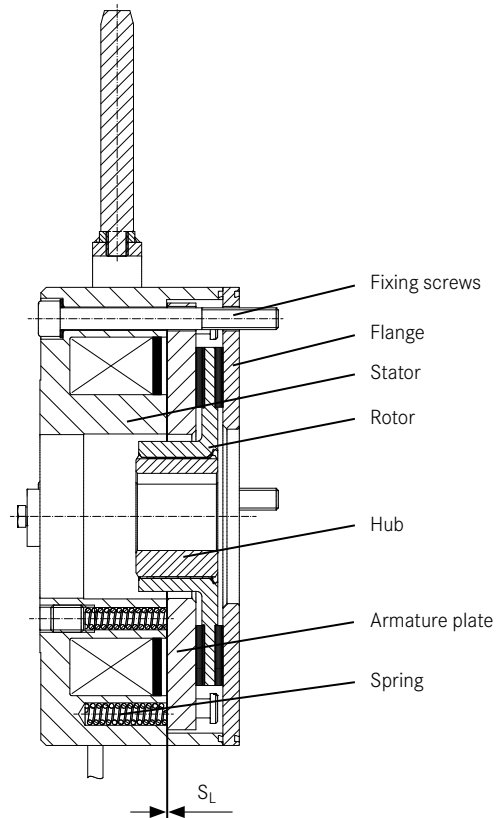

### Noise-reduced aluminium rotor

The rotor with a toothed intermediate ring made of plastic reduces the rattling that can occur in the rotor-hub connection as a result of load oscillations or untrue running in the motor. At the same time this increases the service life of the connection.

#### Features and benefits

- Low wear between rotor and hub
- Recommended for frequency inverter operation
- Noise-reduced design
- Can also be combined with the CCV option





# Rated torques

## General information

INTORQ brakes are designed so that the rated torques specified for 100r/min can be achieved after a short run-in period. This is ensured by using tightly toleranced components and a controlled assembly process.

Deviations from the specified braking torques are possible as a result of varying environmental conditions and fluctuations in the properties of the organic friction linings being used. These possible deviations should be allowed for by taking the appropriate precautions in the dimensioning process.

Increased breakaway can occur especially after long downtimes where there are damp conditions and varying temperatures. The rated torque must be checked if the brake is being used on the customer's own friction surfaces. If the brake is to be used purely as a holding brake with no dynamic load, the friction lining must be reactivated at regular intervals.

## Tolerances in the braking torque

As a result of the tolerances of springs and friction linings, the tolerance range for the braking torque in the BFK470 is

- -15%/+25% for brakes with adjustable spring force (sizes 12 ... 18) and
- -25%/+35% for brakes without adjustable spring force (sizes 06 ... 10).

Speed, temperature and dampness are factors that influence the braking torque. The ideal run-in process requires 10 full cycles of the brake from a speed of 1500r/min with friction work of 50% QE each time. If an adequate run-in process is not possible during commissioning, especially with holding brakes, the braking torque must be increased accordingly in the dimensioning process. INTORQ offers special friction linings for increased torques, quick running-in periods or high braking energies. We welcome the opportunity to review your application and show you how INTORQ can add value to your system and meet any special demands you may have.

## Rated torques

**Rated torque  $M_K$  [Nm] of the brake, rated value at a relative speed of 100 r/min**

Size	06	08	10	12	14	16	18
<b>Operating brake</b>	2	3,5		12			
	2,5	5	9	15			
	3	6	11	18	40	55	100
	3,5	7	14	23	27	50	70
	<b>4</b>	<b>8</b>	<b>16</b>	<b>32</b>	<b>60</b>	<b>80</b>	<b>150</b>
<b>Holding brake with emergency stops</b>	4,5	10	18	36	65	90	165
	5,5	11	21	40	70	100	185
	6	12	23	45	75	105	200
	6,5	14	25	48	80	125	235
	7	15	30	50	100	150	250
	7,5		33	55	110		
<b>On request for project solutions</b>	up to 10	up to 17	up to 46	up to 68	up to 150	up to 200	up to 370

□ Operating brake  
( $S_{Lmax}$  ca.  $2.5 \times S_{LN}$ )

▭ Standard braking torque

▨ Holding brake with emergency stop  
( $S_{Lmax}$  ca.  $1.5 \times S_{LN}$ )

■ For a key to abbreviations see page 4

## Characteristic torques

### Rated torques characteristics

Size	Rated torque $M_K$ [Nm]	Reduction of rated torque at specified speed to x%			Maximum speed $n_{max}$ [r/min]
		1500 r/min	3000 r/min	max.	
06	4	87%	80%	74%	6,000
08	8	85%	78%	73%	5,000
10	16	83%	76%	73%	4,000
12	32	81%	74%	73%	3,600
14	60	80%	73%	72%	3,600
16	80	79%	72%	70%	3,600
18	150	77%	70%	68%	3,600

Speed reduction applies to Standard and WR. For WR linings, see the permissible switching energies listed on page 12.

The permissible maximum speed relates to the standard friction lining  
For a key to abbreviations, see page 4

## Friction lining variants

### Standard and wear-resistant linings

The listed torque ratings and permissible friction work can be combined with any of the brake design options. The catalogue variants are available from a quantity of 1 up to series production levels.

#### ST (Standard)

- For universal use
- Large speed range
- Short run-in process required
- Can be used as holding brakes or operating brakes

#### WR (wear-resistant)

- Long service life
- Can be used in standard applications
- Restricted maximum speed
- Short run-in process required
- Best for use as a an operating brake

### Project solutions

For project solutions INTORQ develops customised series production products on the basis of the customer's technical specifications. The following friction lining qualities are available for project solutions in addition to the catalogue variants:

#### HFC (high friction coefficient)

- For higher braking torques
- For use as a holding brake
- Short run-in process required

#### RIF (run in free)

- Stable static torque
- For use as a holding brake
- No run-in needed
- Developed for high demands
- Restricted maximum speed

#### HT (high temperature)

- Friction lining resistant to high temperatures to allow friction work up to a factor of 5 (compared with the standard aluminium rotor)
- Stable static torque
- Resistant to the effects of dampness and humidity

# Technical data

## Rated data

Size	$P_N$ [W]	$s_{LN}$ [mm]	$s_{L \max}$ [mm] Operating brake	$s_{L \max}$ [mm] Holding brake
06	20	0,2	0,5	0,3
08	25	0,2	0,5	0,3
10	30	0,2	0,5	0,35
12	40	0,3	0,6	0,45
14	60	0,3	0,75	0,45
16	68	0,3	0,80	0,50
18	85	0,4	1,0	0,65

For a key to abbreviations see page 4

## Operating times

The listed operating times are guide values which apply to DC switching with rated air gap  $s_{LN}$ , warm coil and standard characteristic torque.

The times specified are mean values. The engagement time  $t_1$  is approximately 8 to 10 times longer for AC switching.

Size	Characteristic torque $M_K$ [Nm]	$Q_e$ [J]	$s_{hue}$ [1/h]	Operating times [ms]			
				Connection on the DC side			Disconnection
				$t_{11}$	$t_{12}$	$t_1 = t_{11} + t_{12}$	$t_2$
06	4	3.000	79	16	25	41	32
08	8	7.500	50	30	26	56	52
10	16	12.000	40	40	46	86	107
12	32	24.000	30	47	34	81	121
14	60	30.000	28	30	47	77	162
16	80	36.000	27	46	62	108	225
18	150	60.000	20	62	92	154	343

Maximum permissible rotational speed referred on standard friction lining

For a key to abbreviations see page 4

Torque time characteristic dependent on excitation voltage

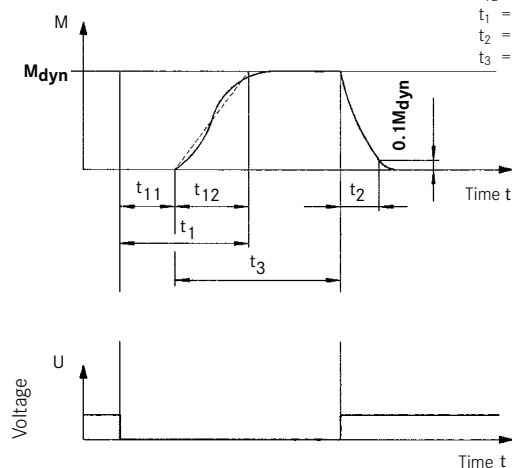

$t_{11}$  = Delay time when connecting  
 $t_{12}$  = Rise time of braking torque  
 $t_1$  = Engagement time  
 $t_2$  = Disengagement time  
 $t_3$  = Slipping time

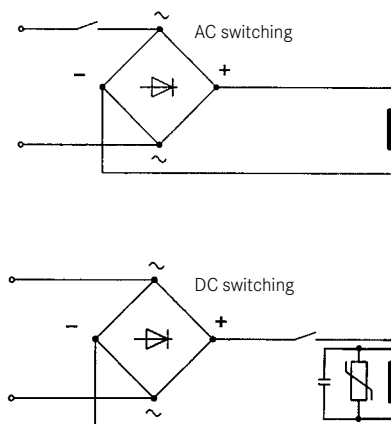

For a key to abbreviations see page 4

## Technical data

### Standard aluminium rotor

The standard rotor can be used without restriction inside the permissible speed and load range. The wear values are dependent on load and speed and can be worked out by using the INTORQ-Select dimensioning tool.

### Aluminium rotor with low rate of wear (WR)

Size	06	08	10	12	14	16	18
<b>Q<sub>E</sub> Maximum permissible friction work per switching cycle [J]</b>							
100 r/min	3,000	7,500	12,000	24,000	30,000	36,000	60,000
1.000 r/min	3,000	7,500	12,000	24,000	30,000	36,000	60,000
1.200 r/min	3,000	7,500	12,000	24,000	30,000	36,000	60,000
1.500 r/min	3,000	7,500	12,000	24,000	30,000	36,000	60,000
1.800 r/min	3,000	7,500	12,000	24,000	30,000	36,000	36,000
3.000 r/min	3,000	7,500	12,000	24,000	18,000	11,000	on request
3.600 r/min	3,000	7,500	12,000	7,000	on request		
Q <sub>BW</sub> [10 <sup>6</sup> J]	85	158	264	530	571	966	1542
S <sub>hue</sub> [h <sup>-1</sup> ]	79	50	40	30	28	27	20

Q<sub>BW</sub> = Friction energy of brake until maintenance  
S<sub>hue</sub> = Transitional operating frequency

In the region of the load limit (operation > 50% Q<sub>E</sub>) the value for Q<sub>BW</sub> can drop as low as 40%.

For a key to abbreviations see page 4



Wind turbines



Industrial trucks



Car wash systems

# Technical data

## Service life and wear

### Friction energy and operating frequency

For the standard (ST) and low-wear (WR) friction linings

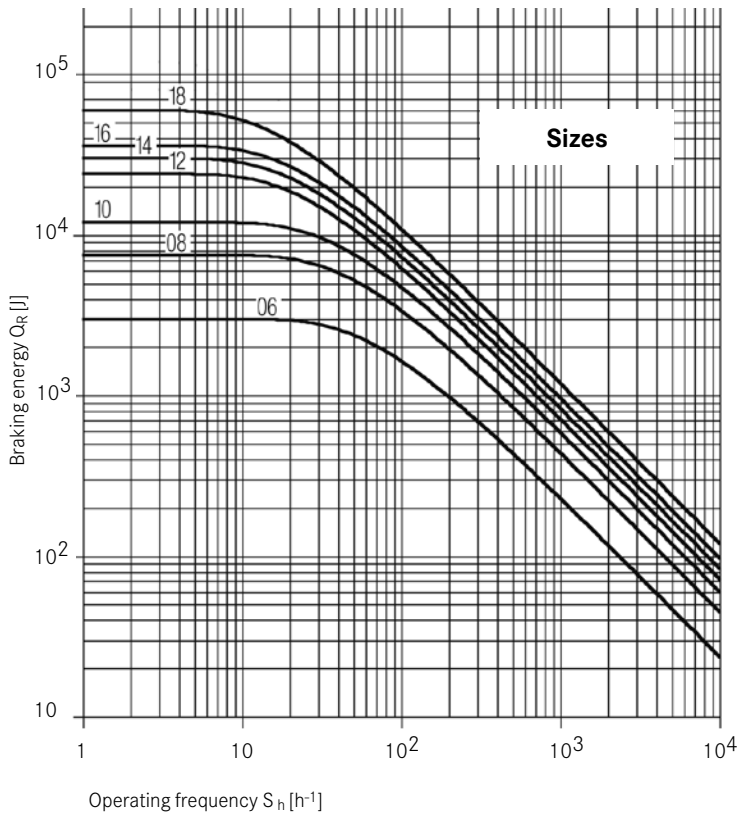

### Maintenance

Brakes are components that are susceptible to wear. When the brake is installed, care must be taken to ensure that it is easily accessible for servicing and maintenance work. The service intervals are to be fixed in accordance with the projected service life and load. Please check the operating instructions for more information.

The friction work that can be accomplished up to the wear limit of the brake depends on a number of factors, especially on the mass to be braked, the braking speed, the operating frequency and the resulting temperature on the friction surfaces. Also, a vertical brake shaft can be expected to increase wear.

The mechanical components of the brake can also limit the service life when there is a low amount of friction work per operation. In particular, the rotor-hub connection, the armature plate and the cylinder pins are subject to operational wear. The expected service life of the standard design is around 2 million load reversals. If a longer service life is required, please contact INTORQ.

$$S_{hmax} = \frac{-S_{hue}}{\ln\left(1 - \frac{Q_R}{Q_E}\right)} \quad Q_{smax} = Q_E \left(1 - e^{-\frac{S_{hue}}{S_h}}\right)$$

The maximum permissible operating frequency,  $S_{hmax}$ , depends on the friction work,  $Q_R$ . A specified operating frequency,  $S_h$ , determines the maximum permissible friction work,  $Q_{smax}$ . Wear increases with high speeds and switching energy because very high temperatures occur for a short time on the friction surfaces.

For a key to abbreviations see page 4

## Product overview

### BFK470 spring-applied brake

<b>Size</b>	<input type="checkbox"/> 06	<input type="checkbox"/> 08	<input type="checkbox"/> 10	<input type="checkbox"/> 12	<input type="checkbox"/> 14	<input type="checkbox"/> 16	<input type="checkbox"/> 18
<b>Design</b>	<input type="checkbox"/> without flange		<input type="checkbox"/> standard flange			<input type="checkbox"/> centering flange	
<b>Voltage</b>	Size 6 – 12						
	<input type="checkbox"/> 24 V	<input type="checkbox"/> 96 V	<input type="checkbox"/> 103 V	<input type="checkbox"/> 170 V	<input type="checkbox"/> 180 V	<input type="checkbox"/> 190 V	<input type="checkbox"/> 205 V
	Size 14 – 18						
	<input type="checkbox"/> 24 V	<input type="checkbox"/> 103 V	<input type="checkbox"/> 180 V	<input type="checkbox"/> 205 V	additional voltages available per request		
<b>Characteristic torque</b>	<input type="checkbox"/> 2 - 370 Nm (see torque ratings on page 9) _____ Nm						
<b>Cable length</b>	<input type="checkbox"/> Size 6 – 14: 400 mm			<input type="checkbox"/> Size 16 – 18: 600 mm			
	<input type="checkbox"/> Special lengths: _____ from 100 – 1000 mm in 100 mm graduations _____ from 1000 – 2500 mm in 250 mm graduations						
<b>Temperature range</b>	<input type="checkbox"/> Standard -20 to +50 °C						
	<input type="checkbox"/> CCV, Cold Climate Version -40 to +50 °C						
<b>Hand release mounted</b>	<input type="checkbox"/> Standard mounting						
<b>Tacho mounting</b>	<input type="checkbox"/> Bores on rear side						
<b>Contactless proximity sensor (available from size 12)</b>	<input type="checkbox"/> Switching function monitoring only available as holding brake (wear monitoring not possible) Information evaluation only for range -25 °C to +120 °C						
<b>Cap</b>	<input type="checkbox"/> Basic version			<input type="checkbox"/> Metal version type			
<b>Shaft sealing ring</b>	<input type="checkbox"/> On request _____ mm						
<b>Rotor</b>	<input type="checkbox"/> Aluminium						
	<input type="checkbox"/> Aluminium, noise reduced (with toothed intermediate ring)						
<b>Hub</b>	<input type="checkbox"/> Bore diameter (see measurements d <sup>H7</sup> on page 6) ∅ _____ mm						
<b>Fixing screw set</b>	<input type="checkbox"/> For mounting with flange			<input type="checkbox"/> For mounting without flange			

## Setting standards in the market, worldwide

We are available to our customers at all times and in all locations. Major customers and projects are supported directly by our Key Account Sales Team at our HQ in Aerzen (Germany) or by our locations in Shanghai (China), Atlanta (USA) and Pune (India).

In addition to this, we work with a global network of local trading partners and cooperate with Lenze's global sales organisation.

Please send service requests directly to your local sales partner or to our HQ in Aerzen, Germany:

E-mail [service@intorq.de](mailto:service@intorq.de)

Tel: +49 5154 70534-444

Fax: +49 5154 70534-200

You can find more information on our products, as well as catalogues and operating instructions available for download, on our website at [www.intorq.de](http://www.intorq.de)



**INTORQ GmbH & Co. KG**

Postfach 1103  
D-31849 Aerzen, Germany

Wülmser Weg 5  
D-31855 Aerzen, Germany

Tel: +49 5154 70534-0  
Fax: +49 5154 70534-200  
E-mail [info@intorq.de](mailto:info@intorq.de)

**INTORQ (Shanghai) CO., LTD**

China

No. 600, Xin Yuan Nan Road,  
Building No. 6 / Zone B  
Nicheng town, Pudong  
Shanghai, China 201306

Tel: +86 21 20363-810  
Fax: +86 21 20363-805  
E-mail [info@cn.intorq.com](mailto:info@cn.intorq.com)

**INTORQ US INC.**

USA

300 Lake Ridge Drive SE  
Smyrna, GA 30082, USA

Tel: +1 678 236-0555  
Fax: +1 678 309-1157  
E-mail [info@us.intorq.com](mailto:info@us.intorq.com)

**INTORQ India Pvt. Ltd.**

India

Plot No. E-7/3, Chakan  
Industrial Area, Phase 3,  
Nighoje, Taluka-Khed,  
Pune, 410501 Maharashtra

Tel: +91 21 3562-5500  
E-mail [info@intorq.in](mailto:info@intorq.in)

[www.intorq.com](http://www.intorq.com)